

Pay and Employment Unit



Department of
**Health, Social Services
and Public Safety**

www.dhsspsni.gov.uk

AN ROINN

**Sláinte, Seirbhísí Sóisialta
agus Sábháilteachta Poiblí**

MÁNNYSTRIE O

**Poustie, Resydènter Heisin
an Fowk Siccar**

**Chief Executive of each HSS Board, HSC Trust
and Special Agencies**

For information:

**Director of Finance
Director of Human Resources,
Director of Medical Services,
Director of Public Health,
Director of Dental Services
of each body**

Room D2.14, Castle Buildings
Belfast
BT4 3SQ
Tel: 028 9052 2817
Fax: 028 9052 8126
Email: john.nesbitt@dhsspsni.gov.uk

Our Ref: Revised HSS (TC8) 3/2007
Date: 11 June 2008

Dear Colleagues

**PAY AND CONDITIONS OF SERVICE FOR HOSPITAL MEDICAL AND DENTAL
STAFF, DOCTORS IN PUBLIC HEALTH MEDICINE AND THE COMMUNITY
HEALTH SERVICE**

Circular HSS (TC8) 3/2007 notified employers of the introduction of the Specialty Registrar grade (StR) including Fixed Term Specialty Training Appointments (StR (FT)) in the Specialty Registrar grade, and of amendments to the national pay and conditions of service in respect of pay on return to training.

It has been brought to the Department's attention that the circular issued in July 2007 did not mention the minimum period of notice required for Specialty Registrars (Fixed Term). I wish to confirm that the minimum period of notice required for Specialty Registrars (Fixed Term) is 1 month, and the necessary amendment has been made to the circular at Annex C (Note 2(a)).

A copy of the circular as amended is attached. Further copies of the circular can be obtained from the Department's website at http://www.dhsspsni.gov.uk/index/hrd/pay_and_employment.htm

Yours sincerely

**John Nesbitt
Assistant Director of Human Resources**

**HUMAN RESOURCES DIRECTORATE
PAY AND EMPLOYMENT UNIT**



Department of

**Health, Social Services
and Public Safety**

An Roinn

**Sláinte, Seirbhísí Sóisialta
agus Sábháilteachta Poiblí**

www.dhsspsni.gov.uk

**Chief Executive of each HSS Board,
HSC Trust, the Central Services
Agency and each Special Agency¹**

Room D.1, Castle Buildings,
Stormont Estate,
BELFAST
BT4 3SR

For information:

Director of Finance
Director of Human Resources
Director of Medical Services
Director of Public Health
Director of Dental Services
of each body

Tel: 028 9052 2344
Fax: 028 9052 2912

eMail: p&e@dhsspsni.gov.uk

**Circular HSS (TC8) 3/2007
(REVISED)**

Our Reference: BC75/07

2 July 2007

Dear Colleague

**PAY AND CONDITIONS OF SERVICE FOR HOSPITAL MEDICAL AND DENTAL
STAFF, DOCTORS IN PUBLIC HEALTH MEDICINE AND THE COMMUNITY
HEALTH SERVICE**

Summary

This circular informs employers of the introduction of the Specialty Registrar grade (StR) including Fixed Term Specialty Training Appointments (StR (FT)) in the Specialty Registrar grade, and of amendments to the national pay and conditions of service of hospital medical and dental staff and doctors in public health medicine and the community health service in respect of pay on return to training.

Agreement

¹ Health and Social Services Boards, HSC Trusts, the Central Services Agency (CSA) the Health Promotion Agency, the Northern Ireland Blood Transfusion Service Agency, the Northern Ireland Regional Medical Physics Agency, the Northern Ireland Guardian Ad Litem Agency, the Northern Ireland Practice & Education Council for Nursing and Midwifery & Health Visiting (NIPEC), Northern Ireland Social Care Council (NISCC), the Northern Ireland Medical and Dental Training Agency (NIMDTA) and the Northern Ireland Health Regulation and Improvement Authority.

1. The Joint Negotiating Committee (Juniors) has agreed the pay scales and model contract documentation for the new Specialty Registrar (StR) and for Fixed Term Specialty Training Appointments in the Specialty Registrar grade (StR (FT)). Pay scales for locum StR and locum StR (FT) have yet to be agreed and will be published separately.
2. The Staff and Associate Specialist Negotiating Committee, Joint Negotiating Committee (Juniors) and Joint Negotiating Committee (Seniors) have agreed amendments to the TCS regarding the pay arrangements on return to training – (see Annex D).

Effective Date

3. The new pay scales and pay codes for the StR and StR (FT) grades will come into effect immediately and should be used for all new appointments to these grades.

Action

4. The revised contract documentation, which replaces that issued as Circular HSS TC(8) 1/2001 is applicable to all training grades and should be used with immediate effect.
5. The new arrangements for pay on return to training will apply to posts entered on or after 1 August 2007. Employees already paid under existing arrangements should continue to be so paid for the duration of any contract of employment made before that date. Further guidance on the new arrangements for pay on return to training, including worked examples, will be published in a future pay circular.

Recommended Action

6. A High Court judgment in 2006 highlighted the need for employers to take all reasonable steps to ensure that the effects of nationally negotiated collective agreements are incorporated into individual contracts of employment.
7. It is good practice that employers should write to individual medical and dental practitioners in order to notify them of the revisions to their TCS.

Points to Note: Terms and Conditions of Service for Foundation House Officers, Specialty Registrars and Specialty Registrars in Fixed Term Appointments

8. Terms and Conditions of Service are being amended to include those training grades not explicitly covered by the current documentation. A further Pay Circular setting out the necessary changes to the TCS will be issued in due course.

9. References to the closed grades of Registrar and Senior Registrar will be removed from future Pay Circulars. Where in the past reference has been made to appointments using the top of the Registrar scale as a standard, to maintain consistency such references should in future be taken to refer to the fifth point (Point 04) of the Specialty Registrar scale.
10. For the sake of completeness, details of pay scales for GP Registrars have also been included in this Circular. These pay scales are still subject to formal approval by the Department and will be implemented, in due course, by the issue of a further circular.

Enquiries

11. Employees should direct personal enquiries to their employer. Any enquiries that cannot be resolved locally should be directed to Pay and Employment Unit or by email to: p&e@dhsspsni.gov.uk.

Further copies

12. Copies of this circular can be obtained from the Department's website at <http://www.dhsspsni.gov.uk/index/hrd/payandemployment.htm>

Yours sincerely

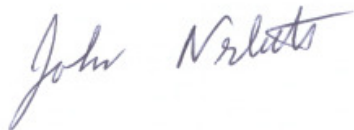

JOHN NESBITT

Assistant Director of Human Resources

Annex A:
StR and StR (FT) – full time trainee pay rates

Table 1: Specialty Registrar (StR) and Fixed Term Specialty Registrar (StR (FT)) Pay Scales

Basic Salary (£)											
Grade	Pay Scale Code	Min	1	2	3	4	5	6	7	8	9
StR (FT)	M240	28,118	29,879	32,338	33,825	35,619	37,413				
StR	M241	28,118	29,879	32,338	33,825	35,619	37,413	39,207	41,001	42,795	44,581

Table 2: Total Salaries for Specialty Registrar (StR) and Fixed Term Specialty Registrar (StR (FT))

Grade	Point	Basic salary	Banding supplement				
			1C 20%	1B 40%	1A & 2B 50%	2A 80%	3 100%
StR (FT) (M240)	Min	£28,118	£33,742	£39,366	£42,177	£50,613	£56,236
	1	£29,879	£35,855	£41,831	£44,819	£53,783	£59,758
	2	£32,338	£38,806	£45,274	£48,507	£58,209	£64,676
	3	£33,825	£40,590	£47,355	£50,738	£60,885	£67,650
	4	£35,619	£42,743	£49,867	£53,429	£64,115	£71,238
	5	£37,413	£44,896	£52,379	£56,120	£67,344	£74,826
StR (M241)	Min	£28,118	£33,742	£39,366	£42,177	£50,613	£56,236
	1	£29,879	£35,855	£41,831	£44,819	£53,783	£59,758
	2	£32,338	£38,806	£45,274	£48,507	£58,209	£64,676
	3	£33,825	£40,590	£47,355	£50,738	£60,885	£67,650
	4	£35,619	£42,743	£49,867	£53,429	£64,115	£71,238
	5	£37,413	£44,896	£52,379	£56,120	£67,344	£74,826
	6	£39,207	£47,049	£54,890	£58,811	£70,573	£78,414
	7	£41,001	£49,202	£57,402	£61,502	£73,802	£82,002
	8	£42,795	£51,354	£59,913	£64,193	£77,031	£85,590
9	£44,581	£53,498	£62,414	£66,872	£80,246	£89,162	

**Annex A: Table 3
StR and StR (FT) – flexible trainee pay rates**

StR (FT)						
Basic						
Point	0	1	2	3	4	5
F5	14,059	14,940	16,169	16,913	17,810	18,707
F6	16,871	17,928	19,403	20,295	21,372	22,448
F7	19,683	20,916	22,637	23,678	24,934	26,190
F8	22,495	23,904	25,871	27,060	28,496	29,931
F9	25,307	26,892	29,105	30,443	32,058	33,672
FC (20% supplement)						
	Min	1	2	3	4	5
F5	16,871	17,928	19,403	20,296	21,372	22,449
F6	20,246	21,514	23,284	24,354	25,647	26,938
F7	23,620	25,100	27,165	28,414	29,921	31,428
F8	26,994	28,685	31,046	32,472	34,196	35,918
F9	30,369	32,271	34,926	36,532	38,470	40,407
FB (40% supplement)						
	Min	1	2	3	4	5
F5	19,683	20,916	22,637	23,679	24,934	26,190
F6	23,620	25,100	27,165	28,413	29,921	31,428
F7	27,557	29,283	31,692	33,150	34,908	36,666
F8	31,493	33,466	36,220	37,884	39,895	41,904
F9	35,430	37,649	40,747	42,621	44,882	47,141
FA (50% supplement)						
	Min	1	2	3	4	5
F5	21,089	22,410	24,254	25,370	26,715	28,061
F6	25,307	26,892	29,105	30,443	32,058	33,672
F7	29,525	31,374	33,956	35,517	37,401	39,285
F8	33,743	35,856	38,807	40,590	42,744	44,897
F9	37,961	40,338	43,658	45,665	48,087	50,508

StR									
Basic									
0	1	2	3	4	5	6	7	8	9
14,059	14,940	16,169	16,913	17,810	18,707	19,604	20,501	21,398	22,291
16,871	17,928	19,403	20,295	21,372	22,448	23,525	24,601	25,677	26,749
19,683	20,916	22,637	23,678	24,934	26,190	27,445	28,701	29,957	31,207
22,495	23,904	25,871	27,060	28,496	29,931	31,366	32,801	34,236	35,665
25,307	26,892	29,105	30,443	32,058	33,672	35,287	36,901	38,516	40,123
FC (20% supplement)									
Min	1	2	3	4	5	6	7	8	9
16,871	17,928	19,403	20,296	21,372	22,449	23,525	24,602	25,678	26,750
20,246	21,514	23,284	24,354	25,647	26,938	28,230	29,522	30,813	32,099
23,620	25,100	27,165	28,414	29,921	31,428	32,934	34,442	35,949	37,449
26,994	28,685	31,046	32,472	34,196	35,918	37,640	39,362	41,084	42,798
30,369	32,271	34,926	36,532	38,470	40,407	42,345	44,282	46,220	48,148
FB (40% supplement)									
Min	1	2	3	4	5	6	7	8	9
19,683	20,916	22,637	23,679	24,934	26,190	27,446	28,702	29,958	31,208
23,620	25,100	27,165	28,413	29,921	31,428	32,935	34,442	35,948	37,449
27,557	29,283	31,692	33,150	34,908	36,666	38,423	40,182	41,940	43,690
31,493	33,466	36,220	37,884	39,895	41,904	43,913	45,922	47,931	49,931
35,430	37,649	40,747	42,621	44,882	47,141	49,402	51,662	53,923	56,173
FA (50% supplement)									
Min	1	2	3	4	5	6	7	8	9
21,089	22,410	24,254	25,370	26,715	28,061	29,406	30,752	32,097	33,437
25,307	26,892	29,105	30,443	32,058	33,672	35,288	36,902	38,516	40,124
29,525	31,374	33,956	35,517	37,401	39,285	41,168	43,052	44,936	46,811
33,743	35,856	38,807	40,590	42,744	44,897	47,049	49,202	51,354	53,498
37,961	40,338	43,658	45,665	48,087	50,508	52,931	55,352	57,774	60,185

Annex B

Appointment to Specialty Registrar posts – Transitional Arrangements

Principles of Transition

- 1) Transition will last from 1st August 2007 until all doctors holding Senior House Officer (SHO) training contracts at that time have completed those contracts or have taken up a Specialty Registrar (StR) post. Thereafter, for doctors entering a training post where previous experience is at SHO level only, starting salary and incremental date will be determined by the existing provisions of paragraphs 130 and 133 of Terms and Conditions of Service (TCS), in which references to Specialist Registrar (SpR) will be amended to include the StR grade. On transition,
 - ◆ doctors on point 0 of the F2 or SHO scales will move to the minimum of the StR scale and take the date of the move as their new incremental date.
 - ◆ doctors on points 1 and 2 of the F2 or SHO scales taking up an StR appointment will transfer to the proposed StR scale at the next highest point above their existing salary, and retain their existing incremental date.
 - ◆ doctors on points 3 and higher of the SHO scale will transfer to the proposed StR scale under the provisions as currently set out in paragraph 133c of TCS.

Following transition

- 2) A doctor's incremental date will remain as on first appointment to the StR grade whether to a FT or a numbered StR post. Although the two scales have different maxima, they will be treated for all intents and purposes as a single grade, and a movement from FT to a numbered post will not be treated as a promotion. However, all service as a FT StR, as a locum in the StR grade, or in a higher grade, will count as set out in paragraph 123a of TCS for incremental purposes when starting salary in a numbered StR post is determined.

Annual Leave

- 3) No change has been made to the annual leave entitlement, which remains at 5 weeks for those on the minimum, first or second incremental points of the StR/SpR scale (mirroring the current SpR provisions) except that those SHOs assimilated to the FT scale will be able to access the enhanced leave provision once they move beyond the second incremental point of the StR scale.

Implementation

- 4) The process for movement between scales under the provisions of paragraph 133c of Terms and Conditions of Service is complex and widely misunderstood. Assimilation extends the facility to retain an incremental date to those doctors on points 1 and 2 of the SHO scale. A flowchart and several representative but not exclusive examples have been developed to enable a better understanding of the process.

Annex B

Appointment to Specialty Registrar posts – Transitional Arrangements

Flowchart 1 – basic method of assimilation

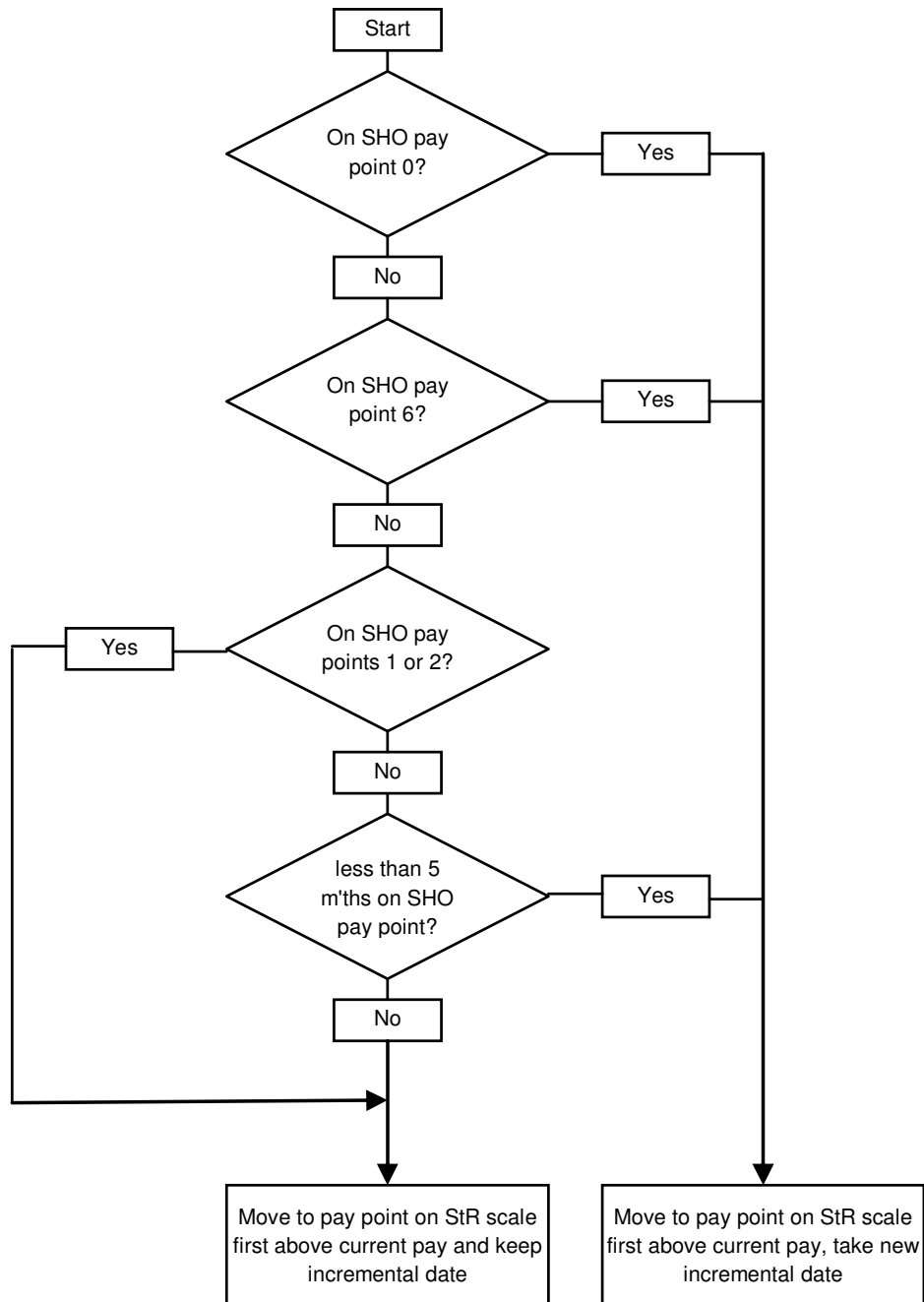

Annex B

Appointment to Specialty Registrar posts – Transitional Arrangements

NON-EXHAUSTIVE EXAMPLES OF TRANSITIONAL ARRANGEMENTS AND TRANSFER

Example 1

A doctor, having been on point 4 of the SHO scale for 1 month, will transfer to point 3 of the StR scale (the first point with a higher value than SHO4), take the date of transfer as their new incremental date, and move 12 months later to point 4 of the StR scale.

Example 2

A doctor, having been on point 4 of the SHO scale for 11 months, will transfer to point 3 of the StR scale, retain their existing incremental date and move 1 month later to point 4 of the StR scale.

Example 3

A doctor, having been on point 4 of the SHO scale for 11 months and 29 days, will transfer to point 3 of the StR scale, retain their existing incremental date and move 1 day later to point 4 of the StR scale.

Example 4

A doctor, having been on point 4 of the SHO scale for 12 months and transferring to an StR post on their incremental day, will move to point 3 of the StR scale, retain their existing incremental date, and move on the same day to point 4 of the StR scale.

Breaks in service at transfer

- 5) It has been suggested that some doctors may not start in specialty training posts immediately after the beginning of August and might as a consequence be faced with a break in service before taking up their new post. While this is unlikely to happen in practice on a significant scale given the need to maintain service cover, it is useful to consider the effect of a break in service on incremental dates for pay purposes – short breaks will not normally count as a break in service for the purpose of occupational benefits.
- 6) If a doctor takes time out of HPSS service, that time will be discounted when establishing their incremental date on taking up their new appointment, if they fall into the group that retains their incremental date on transfer. However, if such a doctor spends some or all of the period between substantive appointments working, for example, as a locum, then that time will be counted as additional service when the incremental date is re-calculated and, if by including such service the doctor would have reached an incremental point during the period of locum work, adjustment should be made to the notional SHO salary on transfer when the StR appointment is taken up.

Example 1

A doctor has a period of ten days without a post, during which time he takes a break. The effect will be to set back his incremental date by ten days. If his incremental date fell on the sixth day of the ten day period, he would need to work for five days after his return before gaining an increment, assuming he would normally have retained his incremental date on transfer.

Example 2

A doctor has a period of 3 months between leaving her SHO post and taking up an StR appointment. During that time she works for two months as a locum in a transitory SHO-level post. On taking up the StR appointment she will have set back her incremental date by only one month, as time spent in the locum post will be counted as equivalent to continuing SHO service (paragraph 123a, TCS).

Annex B

Appointment to Specialty Registrar posts – Transitional Arrangements

Example 3

A doctor spends a period of a little over three months between leaving his SHO post and taking up an StR appointment working as a locum providing maternity cover in a Specialty Registrar post (or indeed as an StR locum for service). In this case the doctor could elect to count the full period as continuing service in the SHO grade and retain his existing incremental date, or could elect to set back his incremental date by the period of the break and to count the locum period at half rate against seniority in the StR grade on appointment (under paragraph 123b of TCS), whichever was the more favourable.

Example 4

A doctor, on SHO point 4 finishes her SHO post 2 weeks before her incremental date. In the period before taking up an StR appointment four weeks later she works for three weeks as a locum. Counting her locum service as continuing SHO service, she will have been due an increment during the break, and her starting salary in the StR post will be based on transfer from point 5 of the SHO scale. As she will have been on that point for only a matter of weeks, calculation of a new incremental date as a result of service during the break becomes academic; she will take the date of transfer as her new incremental date.

Flowchart 2 – Effect of a break in service on incremental date

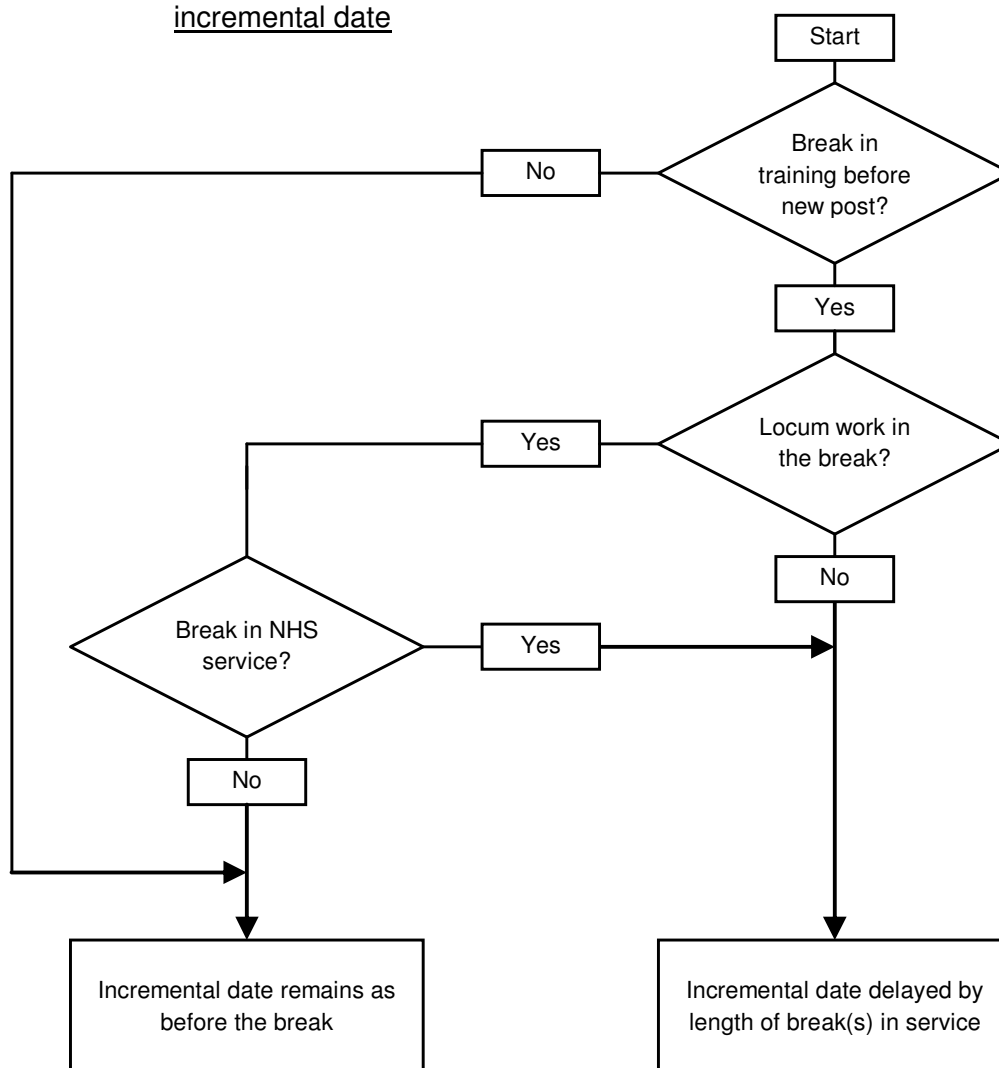

Annex C

OFFER AND ACCEPTANCE OF A TRAINING POST

STATEMENT OF PARTICULARS OF EMPLOYMENT FORMING PART OF THE CONTRACT FOR HOSPITAL MEDICAL AND DENTAL STAFF IN THE GRADES OF SPECIALTY REGISTRAR, SPECIALIST REGISTRAR, SENIOR HOUSE OFFICER, FOUNDATION HOUSE OFFICER, HOUSE OFFICER AND PRE-REGISTRATION HOUSE OFFICER AND DOCTORS IN PUBLIC HEALTH MEDICINE AND THE COMMUNITY HEALTH SERVICE

For Specialist and Specialty Registrars it will be necessary to incorporate into the model contract below, paragraphs as appropriate from the previous model contract required specifically for SpRs as per HSS (TC8) 2/96 or its successor.

[Insert: Name and address of employing authority/Trust]

Date.....

Dear

Offer of appointment

1. (a) I am instructed by the [insert name of employing Board/Trust] to [offer you]* [confirm the offer of]* an appointment as [insert job title and grade] at [insert name of hospital(s)] commencing on [for a period of terminating on].*
- (b) The date of the start of your period of continuous employment is For these purposes, your employment with [insert name of previous employer] [is]* [is not]* included in the period of continuous employment.

Applicable collective agreement

2. Your appointment will be subject to the Terms and Conditions of Service of Hospital Medical and Dental Staff and Doctors in Public Health Medicine and the Community Health Service (Northern Ireland) as amended from time to time [and any reference in those Terms and Conditions to an employing Board shall be construed as if it were to include a reference to an employing Authority].*

Duties

3. (a) Your hours and duties are as defined in the attached job description (For rotations, the job description may differ for each individual post/placement). You will be available for duty hours which in total will not exceed the duty hours set out for your working pattern in paragraph 20 of the Terms and Conditions of Service.
- (b) Your working pattern is described as [full shift]* [partial shift]* [24 hour partial shift]* [on-call rota]* [hybrid comprising [full shift]* [partial shift]* 24 hour partial shift]* [on-call rota]*] with controls on hours as defined in the Terms and Conditions of Service paragraph 20.

[For staff contracted as full-time staff

- (c) You will receive a base salary as detailed in Table 1, Appendix 1 of the Terms and Conditions of Service.]*

[For staff contracted as part-time staff

- (c) You will receive a basic salary determined by your actual hours of work as a proportion of the full-time basic salary as detailed in Table 1, Appendix 1 of the Terms and Conditions of Service, using the principles set out in '*Equitable Pay for Flexible Medical Training*' (HSS(TC8) 1/2005).]*

Annex C

- (d) A non pensionable supplement at payband *[insert payband]* will be payable in accordance with paragraph 22 of the Terms and Conditions of Service (for rotations, banding supplements may differ for each individual post/placement).
- (e) Banding supplements may be altered (in accordance with paragraphs 6(e) and 7(c) below) in the light of changes in working patterns in order to make posts compliant with the New Deal and the Working Time Regulations as amended. If the payband changes, you will be issued with a letter of variation (in accordance with paragraph 7 below). Pay protection will apply in accordance with paragraph 21 of the Terms and Conditions of Service.

Pay

- 4. (a) Your base salary will be £ *[insert figure]* per annum, paid monthly [and will progress by annual increments to £ *[insert figure]* per annum]* in accordance with the current national agreed salary scale for your grade. (These rates are subject to amendment from time to time by national agreement.) See Note 1.
- [(b) Your incremental date will be *[insert date]*]*
- [(c) You will receive, in addition to your base salary a supplement at the rate of% of your base salary for duty contracted at [Band 1 A/B/C]* [Band 2 A/B]* [Band 3]* [Band FA/FB/FC]* as set out in Paragraph 3(d) above, which will be payable monthly. (These rates may be amended from time to time by national agreement).]*

Pension

- 5. (a) Your appointment will be pensionable and your base salary will be subject to deduction of superannuation contributions in accordance with the HPSS Superannuation Scheme unless you opt out of the scheme. (Any supplement payable to you is not pensionable.) Details of the HPSS Superannuation Scheme are given in the scheme guide.
- (b) There [is]* [is not]* a contracting out certificate in force for the purposes of the Employment Rights (NI) Order 1996.
- (c) Pay supplements over and above base salary are non-pensionable.
For staff contracted to work 40 or more hours of duty per week:
- (d) Your pensionable pay for contributions purposes must be based on your actual whole-time basic pay (1.0) only.
For staff contracted to work less than 40 hours of duty per week:
- (e) Your pensionable pay for contributions purposes will be the appropriate proportion of actual whole-time basic pay (1.0). However, your contributions must also be paid on any additional hours of duty you work between your contracted hours and a maximum of 40 hours per week.
- (f) Your employer must make arrangements to track and record these additional hours (see Paragraph 5(e) above) for pension purposes.

Monitoring of working patterns

- 6. (a) The Trust is contractually obliged to monitor junior doctors' New Deal compliance and the application of the banding system, through robust local monitoring arrangements supported by guidance. You are contractually obliged to co-operate with those monitoring arrangements.

Annex C

- (b) These arrangements will be subject to:
 - review by the improving junior doctors working lives implementation support group; and
 - for employers, the performance management systems.
- (c) The Trust must collect and analyse data sufficient to assess hours' compliance and/or to resolve pay or contractual disputes. Therefore, when your employer reasonably requests you to do so, you must record data on hours worked and forward that data to your employer.
- (d) The Trust is required to ensure that staff in all training grades comply with the controls on hours of actual work and rest detailed in sub-paragraph 22.a of the Terms and Conditions of Service, and with the requirements of the Working Time Regulations as amended from time to time.
- (e) You are required to work with your employer to identify appropriate working arrangements or other organisational changes in working practice which move non-compliant posts to compliant posts and to comply with reasonable changes following such discussion.

Revision to pay banding

- 7. (a) The Trust will notify you in writing of its decision on banding.
- (b) Full details of the procedure for appealing against banding decisions are in the Terms and Conditions of Service sub-paragraph 22.l.
- (c) Full details of the procedure for rebanding posts are in the Terms and Conditions of Service sub-paragraph 22.m.

Notice

- 8. You are entitled to receive notice of termination of employment and are required to give [insert name of employing Board/Trust] notice. See also Note 2.

Registration and insurance

- 9. You are required to be registered with the [General Medical Council]* [and]* [General Dental Council]* throughout the duration of your employment. See also Note 3.

Additional work

- 10. You agree not to undertake locum medical or dental work for this or any other employer where such work would cause your contracted hours (or actual hours of work) to breach the controls set out in paragraph 20 of the Terms and Conditions of Service.

Residence

- 11. [The appointment requires you to be resident at [insert name of hospital]. No charge will be made for lodgings, in accordance with the Terms and Conditions of Service.

See also Note 4]*

[The appointment requires you to be resident in [insert name of hospital house or flat]. The terms of your occupation are set out in the enclosed tenancy agreement/licence.

See also Note 4]*

[The appointment does not require you to reside in hospital, but you have chosen to do so; and a deduction from salary for lodgings will accordingly be made, in accordance with the Terms and Conditions of Service.

Annex C

See also Note 4]*

[The appointment does not require you to reside in hospital, but you have chosen to do so; and the terms of your occupation of [insert address of hospital house or flat] are set out in the enclosed tenancy agreement/ licence.

See also Note 4]*

[It is your responsibility to ensure that when on call you will be available by telephone and able to reach your hospital in time to meet your clinical commitments]*

Leave

12. (a) You will be entitled to weeks' annual leave with full pay each year. The Trust's leave year runs from
- (b) In the current leave period [insert dates] your entitlement will be weeks.
- (c) Full details of both annual leave and sick leave allowances and the conditions governing those allowances and study leave, are set out in the Terms and Conditions of Service.

Property

13. (a) [Insert name of employing Board/Trust] accepts no responsibility for damage to or loss of personal property, with the exception of small valuables handed to their officials for safe custody. You are therefore recommended to take out an insurance policy to cover your personal property.
- (b) Notwithstanding (a) above, [Insert name of employing authority/Trust] undertakes, so far as is reasonably possible, to ensure that lodgings are maintained in a secure condition.
- (c) You should, through the exercise of normal diligence, also seek to maintain the security of your lodgings.

Deductions

14. The [insert name of employing Board/Trust] will not make deductions from or variations to your salary other than those required by law without your express written consent.

Sickness Absence

15. The provisions relating to absence by you because of sickness appear in paragraph 225-244 of the Terms and Conditions of Service.

Grievance procedure

16. (a) Should you have any grievance relating to your employment you are entitled to discuss the matter in the first instance with the consultant (or consultants) to whom you are responsible, and where appropriate to consult, either personally or in writing, with [insert name of the appropriate Personnel Officer], at [insert address of Personnel Officer].
- (b) The agreed procedure for settling differences between you and [insert name of employing Board/Trust] where the difference relates to a matter affecting your Conditions of Service is set out in Section 42 of the General Terms and Conditions of Service (or in any replacement provision which may come into force from time to time).

Annex C

Disciplinary procedure

17. The provisions relating to disciplinary procedure appear in section 42 of the General Terms and Conditions of Service as incorporated by paragraph 189 of the Terms and Conditions of Service.

Acceptance

18. If you agree to accept the appointment on the terms specified above, please sign the form of acceptance on the following page and return it to me. A second signed copy of this is attached, which you should also sign, and retain for your future reference.

Yours faithfully

Signature

On behalf of

Annex C

NOTES

[]*: A square bracket followed by an asterisk indicates “delete as necessary”.

1. Your salary gives years’ incremental credit for previous service. If you have any enquiry about how this has been calculated, please contact [insert name and address of Personnel Officer].

2. (a) The Departments and the profession have agreed that minimum periods of notice should be applied as follows, unless there is agreement by both parties to a contract that a different period should apply:

House Officer..... 2 weeks

Foundation House Officer 1 2 weeks

Foundation House Officer 2 1 month

Senior House Officer 1 month

Specialty Registrar (Fixed Term) 1 month

Specialty or Specialist Registrar 3 months

(b) The Employment Rights (NI) Order 1996 provides entitlement to minimum periods of notice, dependent upon an employee’s length of continuous employment, as follows:

<u>Period of continuous employment</u>	<u>Notice entitlement</u>
1 month or more but less than 2 years	Not less than 1 week
2 years or more but less than 12 years	Not less than 1 week for each year of continuous employment
12 years or more .	Not less than 12 weeks

3. Copies of HSS(TC8) 14/89 and the leaflet on indemnity arrangements issued in December 1989 (are enclosed)* [may be obtained on request]* You are normally covered by the HPSS Hospital and Community Health Services indemnity against claims of medical negligence. However, in certain circumstances (especially in services for which you receive a separate fee) you may not be covered by the indemnity. The Health Departments therefore advise that you maintain membership of your medical defence organisation.

4. Copies of the guidance on the standards of residential accommodation [are enclosed]* [may be obtained on request]*.

5. Copies of HSS(TC8) 12/2000 – Modernising Pay and Contracts for Hospital Doctors and Dentists in Training, [are enclosed]* [may be obtained on request]*.

PLEASE DO NOT DETACH

I hereby [accept]* [confirm my acceptance of]* the offer of appointment mentioned in the foregoing letter on the terms and subject to the conditions referred to in it.

Signature

Date

This offer, and acceptance of it, shall together constitute a contract between the parties.

Annex D

Pay Protection on Re-Entry to Training from a Career Grade Post

Changes to Terms and Conditions of Service

- 1) The pay protection provisions on return to training are to be harmonised across Hospital Medical and Dental Staff and Doctors in Public Health Medicine and the Community Health Service. The following paragraphs replace paragraphs 132 and paragraph 135e. Paragraph 135f is deleted. This has been agreed across all craft groups.
- 2) For the purposes of this note and revised paragraphs 132 and 135e the general premises are:
 - ◆ The term 'training grade' refers to accredited training appointments in the grades of FHO, SHO, SpR and StR.
 - ◆ the term 'career grade' is a reference to any HPSS medical practitioner appointment on national terms and conditions of service other than those in training grades.
- 3) On return to a training contract, a doctor will assume the terms and conditions applicable to a doctor in training: but
 - ◆ for pay purposes a doctor may either; be placed on an appropriate point on a training grade pay scale;or
 - ◆ their pay while in the training post may be based on the pay point reached in their career grade contract, with total pay calculated as if their contracted training duties had been carried out under the terms of their previous career grade contract,and

the practitioner retains the current value of the pay point or threshold reached before re-entry to training, receiving general pay awards but not moving up the incremental scale.
- 4) Continuous service of less than 13 months in a substantive career grade post immediately prior to re-entering training will not be recognised for pay protection purposes.
- 5) The 'appropriate authority' recognising posts under paragraph 132 will normally be the responsible Deanery.
- 6) These provisions will come into force with effect from and including 1 August 2007. New contracts of employment agreed after that date will be subject to these new provisions which will apply both to practitioners already protected under current arrangements and to practitioners starting retraining.
- 7) The 13 month qualifying period in the career grade post referred to in the revised paragraph 132 can be discontinuous and may consist of one or more posts, but it must not be broken by a period of any length in a training grade.

Annex D

Pay Protection on Re-Entry to Training from a Career Grade Post

REVISIONS TO PARAGRAPHS 132 and 135e

132. Where a practitioner in a career grade takes an appointment in a training grade which is recognised by the appropriate authority as being for the purpose of obtaining approved training (which may include training to enable the practitioner to follow a career in another specialty) and the practitioner has given continuous service in a career grade post or posts for at least 13 months immediately prior to re-entering training, the practitioner shall, while in the training grade, continue to receive a salary protected on the incremental point or threshold the practitioner had reached in his or her previous career grade appointment. Such a practitioner shall receive the benefit of any general pay awards. On reappointment to a career grade post, the practitioner's starting salary should be assessed as if the period spent in the approved training post had been continuing service in the previous career grade. Where a practitioner re-entering training from a career grade has held a recognised training post (or equivalent service overseas) in the 13 months of contracted employment prior to re-entering training, the intervening period spent in the career grade shall be taken as continuing service in the training grade, and the practitioner will be re-appointed on the appropriate incremental point of the training grade scale. Where pay in the earlier training post was already protected under these provisions, such protection shall continue. Practitioners whose previous appointment was in Great Britain, Isle of Man or Channel Islands hospital service are eligible for protection of salary under the terms of this paragraph.
- 135e. A practitioner entitled to protection under paragraph 132 shall continue to receive the leave entitlement of his or her previous post and shall receive the appropriate training grade salary plus the supplement or his or her protected salary, whichever is the greater, except that where the salary is protected at a point on the training grade scales the supplement for the new post shall be paid in any case. The appropriate training grade salary shall be determined as the point on the training grade incremental scale previously reached, plus recognition of service in the same or a higher grade subject to the provisions of paragraph 123 and such guidance as may be published from time to time. For career grade practitioners entering a training grade, the basic salary paid in the previous appointment shall also, for protection purposes, not include any payments for an additional notional half-day under paragraph 14, additional sessions under paragraph 16, payments for additional Programmed Activities, out of hours or on-call, or a salary supplement, as appropriate, for which the practitioner was contracted in that career grade appointment. The practitioner will, however, be entitled to have total pay in the training post calculated as if the duties contracted for in the training post had been carried out under the relevant terms of the career grade contract held before re-entry to training.

Annex E

Specialty Registrars Training in General Practice

Determination of allowances for doctors entering VTS training in the Specialty Registrar grade.

The following information and table in respect of GP Registrars, is included for the sake of completeness. They show the rate of allowances applicable to the GP Registrar Scheme, subject to formal approval by the Department. These allowances are included for information only, until the amounts are authorised by the Department.

- 1) Doctors appointed from hospital training grades shall have their basic salary as a Specialty Registrar established under the transitional arrangements described in Annex B of Pay Circular HSS(TC8) 4/2007.
- 2) The total allowance can then be calculated by reference to the table below.
- 3) Allowances for those appointed on or after 1 August 2007 will be determined under the arrangements as set out in Annex D of this Pay Circular.

Contracts of employment entered into after 1 April 2007

Col A : Hospital salary (last NHS appointment held) = current GPR basic allowance

Col B : GP Registrar Supplement

Col C : Col A + Col B = total allowance payable to GP Registrar

		A	B	C
		£	£	£
1	Specialty Registrar (StR) minimum	28,118	15,465	43,583
2	2 nd Year StR	29,879	16,433	46,313
4	3 rd year StR	32,338	17,786	50,124
5	4 th year StR	33,825	18,604	52,429
6	5 th year StR (Registrar Maximum)‡	35,619	19,590	55,210
7	6 th year StR	37,413	20,577	57,991
8	7 th year StR	39,207	21,564	60,771
9	8 th year StR	41,001	22,551	63,552
10	9 th year StR	42,795	23,537	66,333
11	10 th year StR	44,581	24,520	69,101